

24 69

P1124**Oxygen Sensing Adaptation Range 1 (Cylinders 1 - 3) Enrichment Limit****P1126****Oxygen Sensing Adaptation Range 1 (Cylinders 4 - 6) Enrichment Limit****Function**

The adaptive oxygen sensing corrects longer lasting deviations of the fuel/air mixture from $\lambda = 1$ through changes of the calculated pilot control within the engine control module and with that the injection time.

Should the correction factor through adaptation exceed a predetermined value, the diagnosis will detect the adaptation limit.

Range 1 covers the engine operating state close to idle.

Diagnostic conditions

- Oxygen sensing is active.
- Time elapsed after engine start-up 250 to 350 seconds.
- Engine temperature $>90^{\circ}\text{C}$.
- Intake air temperature $< 90^{\circ}\text{C}$.
- Air mass flow $< 30 \text{ kg/h}$
- Engine speed $< 920 \text{ }^1/\text{min}$.

DTC No.	Fault conditions	Fault area
P1124 P1126	Fuel/air mixture so lean that the control is at the enrichment lin it.	<ul style="list-style-type: none"> - Intake system leaking. - Fuel pressure too low. - Fuel injectors contaminated. - Volume supply of fuel pump too low.

Note

If DTC P1124 or P1126 (oxygen sensing at enrichment limit) is in the memory, this means that the fuel/air mixture is too lean.

Leakage air ahead of the oxygen sensors can also lead to a fault in adaptation.

Diagnostic procedure

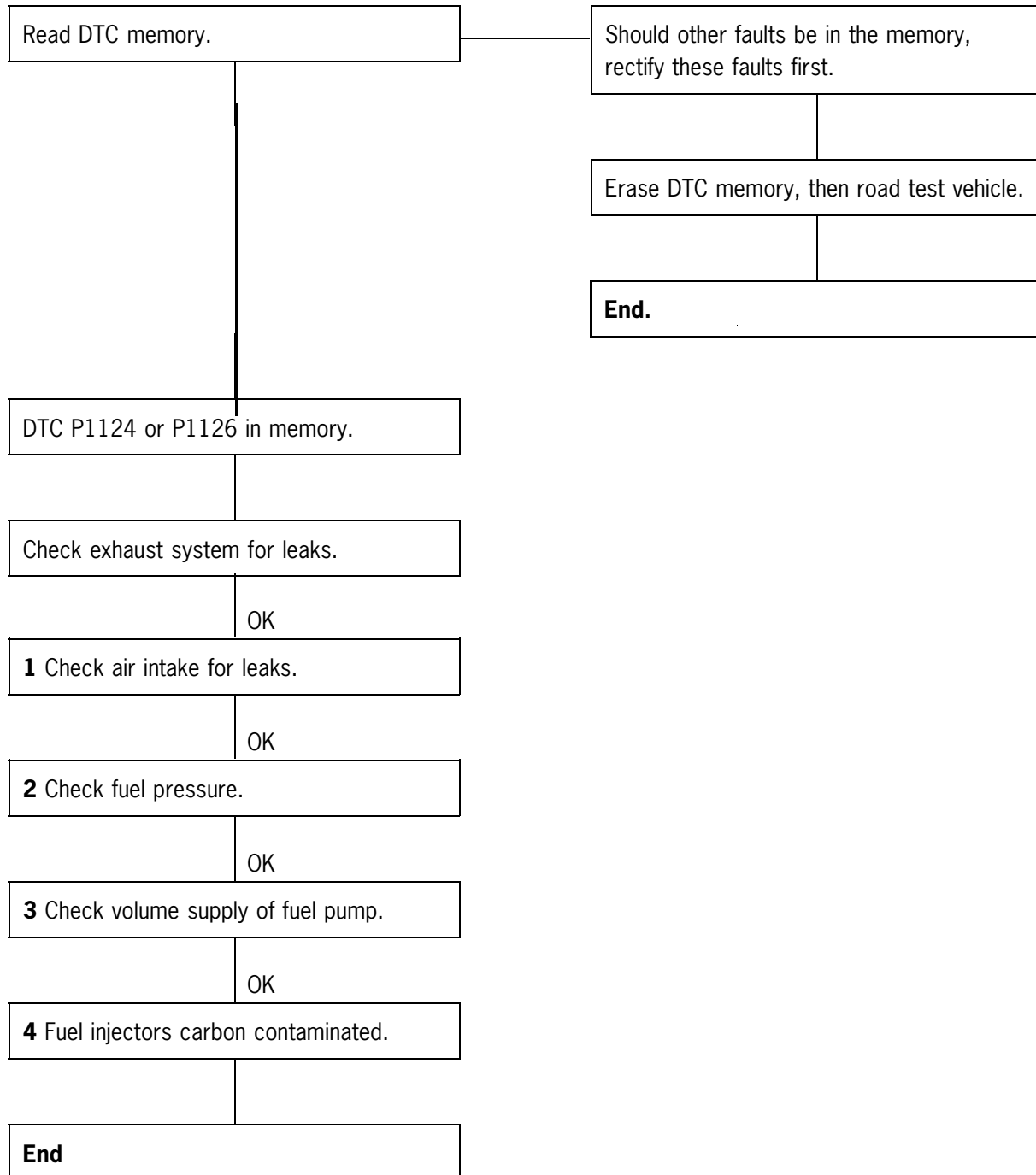

1 Check air intake system for leaks.

1. Remove air cleaner cover and insert.
2. Undo hose clamp on mass air flow sensor with a cross-head screwdriver, e.g. from Messrs. Wiha Order No. 153-1 (350 mm long).

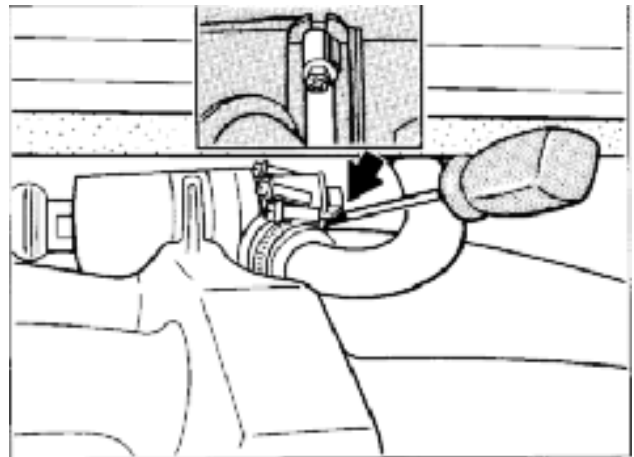

2354 - 24

3. The restricted space available necessitates separation of the mass air flow sensor and air cleaner housing in the engine compartment.
To remove, turn the mass air flow sensor in the direction of the arrow (driving direction), at the same time countering at the air cleaner housing (bayonet lock).

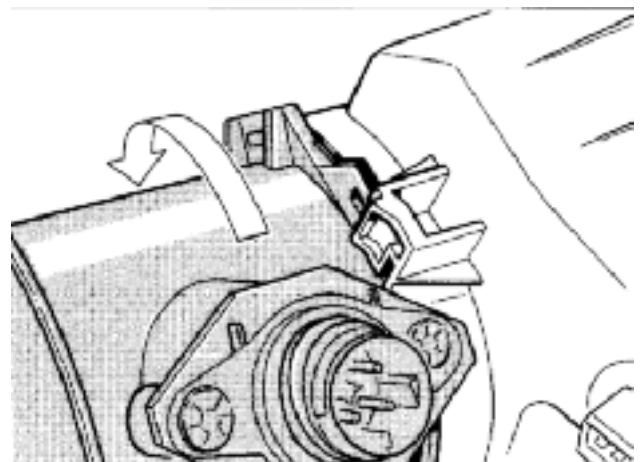

2221 - 24

4. Lever off circlip and remove protective grille.
5. Secure sealing plate 9264/1 on mass air flow sensor using screws M 4 x 40 and washers.

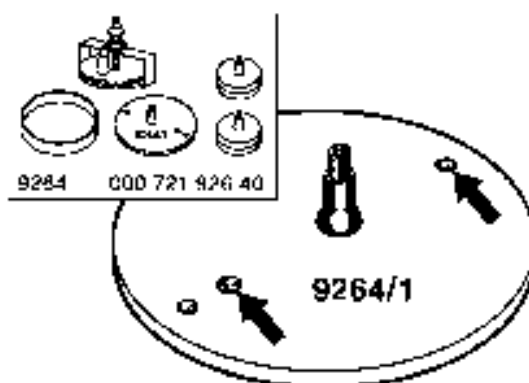

2030 - 20

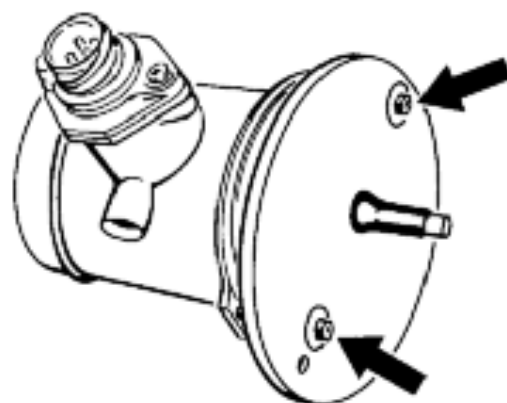

2031 - 20

Note

Check the position of the mass air flow sensor on the sealing plate before finally tightening the screws, i.e. no light gap must be visible upon inspection.

6. Build up a pressure of approx. 0.5 bar.
Large leaks are very audible when the pressure has been built up; small leaks can be made visible using leak spray.

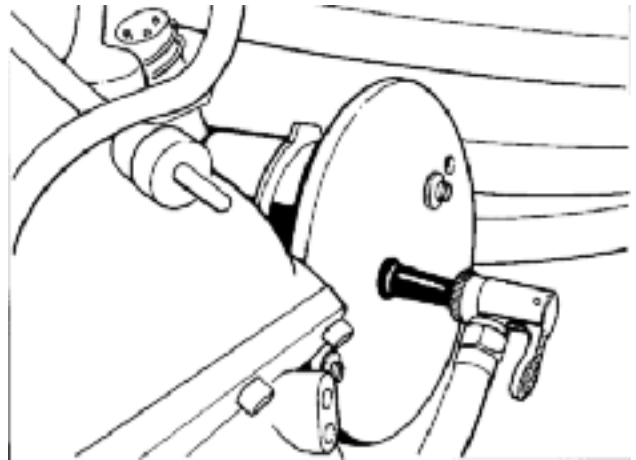

2352 - 24

Note

The pressure relief valve on the oil tank opens at 180 ± 20 mbar.
Block the valve. To do this, remove the front wheel housing liner of the right rear wheel housing. Close off the hose from the oil tank pressure relief valve with a suitable stopper.

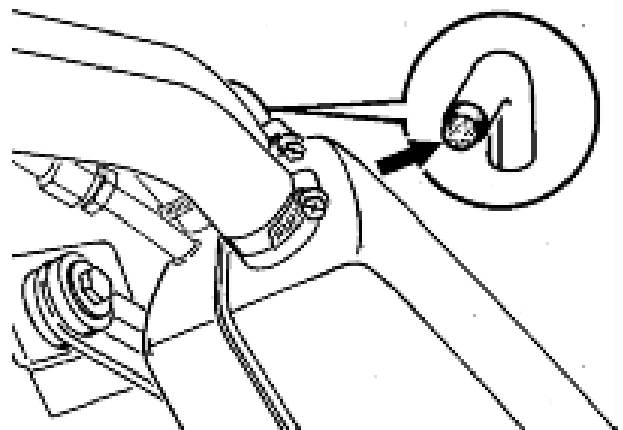

2060-20

Remove the stopper from the hose after carrying out the leak test.

Assemble the mass air flow sensor and air cleaner housing in the engine compartment before attaching the mass air flow sensor to the air intake system.

2 Check fuel pressure.

1. Remove heater blower at the rear left of the engine compartment.
2. Remove valve cover at test connection of fuel distributor line.

Note

The valve cover must be used **only** once.

Tightening torque: **2.5 + 0.5 Nm**

3. Connect pressure gauge P 378 or VW 1318 with attachment line 9559 and connect to test connection.

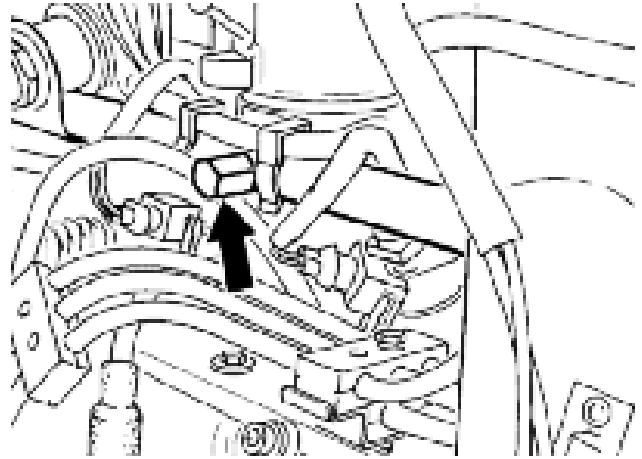

2305 - 24

4. Remove ECM relay (R53) from fuse/relay panel and connect terminals 30 and 87 b with locally manufactured fused jumper cable and trigger fuel pump with system tester.

The fuel pump must work now.

5. Test values:

Engine not running	3.8 ± 0.2 bar
Engine at idle	3.3 ± 0.2 bar



1728 - 20

3 Check volume supply of fuel pump.

1. Remove heater fan at rear left of engine compartment.
2. Remove fuel return line at fuel pressure regulator, making sure that you counter when you do this. Collect remaining fuel.

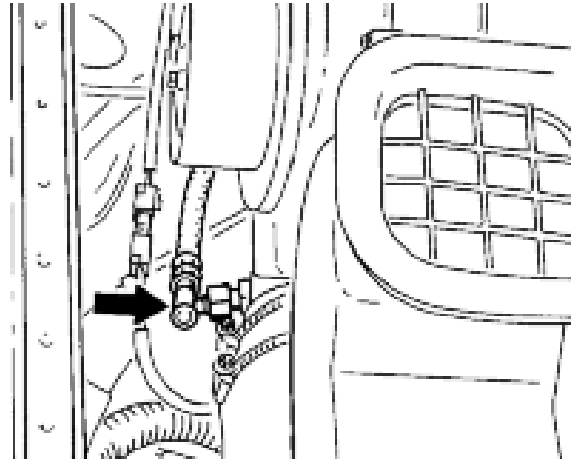

2306 - 24

3. Connect special tool hose 9507, (Order No. 000.721.950.70) to pressure regulator and hold in a measuring vessel.

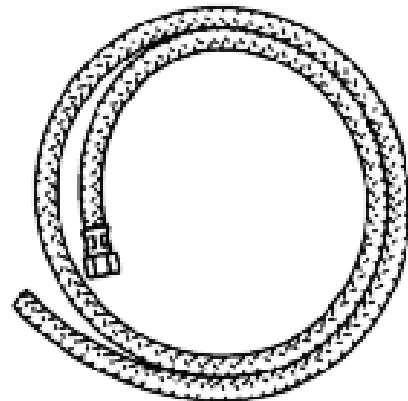

1742 - 20

4. Disconnect ECM relay (R53) from fuse/relay panel and connect terminals 30 and 87 b (labeled 3 and 7 on fuse/relay panel) with locally manufactured fused jumper cable and trigger fuel pump with system tester. The fuel pump must work now.



1728 - 20

5. Allow fuel to flow into a measuring vessel.

Fuel volume supply must be at least

850 cm³/30s, i.e. after these 30 seconds, the measuring vessel must contain at least 850 cm³ fuel.

Note

Observe the safety regulations under all circumstances.

4. Fuel injectors contaminated (carbonized).

1. If checkpoints 1, 2 and 3 are negative, the fuel injectors may be contaminated (carbonized).
2. Clean fuel injectors (ultrasound cleaning device) or replace.