

Technical Bulletin

Model
6 Cyl.

Group
4

Subject
Operating Noise of Hydraulic Brake
Booster Pump

Part Identifier
4761

Number
9506

ATTENTION: Service Manager / Service Technician

Models Affected: 1996 911 Turbo and 911 Carrera 4S

Concern: Excessive operating noise from the hydraulic brake booster pump.

General Information: To reduce the operating noise from the hydraulic brake booster pump, a damper (arrow, Figure1) can be installed between the pump and the brake system accumulator.

Vehicle Information: The damper was introduced in production as of July 14, 1995, with VIN numbers:

994 TS 37 5469	Turbo
995 TS 32 0146	Carrera 4S

Parts Required:

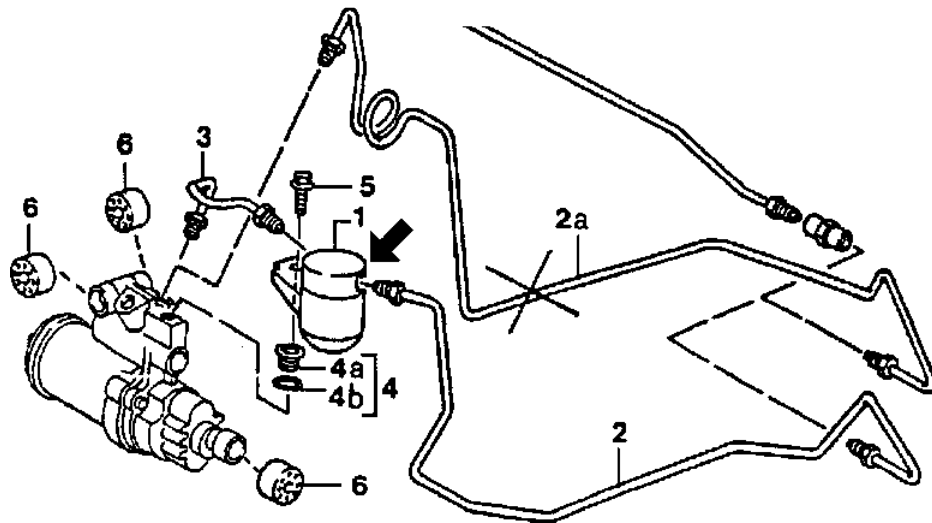

Figure 1

Key	Description	New Part Number	Old Part Number	Note
1	1 x Damper	993 355 123 03		
2	1 x Hydraulic line (long)	993 355 249 04	993 355 249 01	2a Former version
3	1 x Hydraulic line (short)	993 355 247 02		
4(a,b)	1 x Repair Set	993 355 954 00		Plug and O-ring
5	1 x Bolt	900 378 158 09		
6	3 x Bushing	964 355 908 50	964 355 908 00	Former - White New - Black
-	Brake Fluid DOT 4	000 043 202 09		Same Type 200

PORSCHE CARS NORTH AMERICA INC.



Technical Bulletin

Model
6 Cyl.

Group
4

Subject
Operating Noise of Hydraulic Brake
Booster Pump

Part Identifier
4761

Number
9506

Repair Procedure:

If a customer complains that the hydraulic brake booster pump is too loud, the new damper and related parts should be installed.

Important Notes:

- When working on the brake system be certain to maintain absolute cleanliness. Use only lint free shop towels.
- If necessary, clean and dry the outside surfaces of the brake system components to avoid contamination from dirt.
- All rubber seals in the brake system must be lubricated with DOT 4 brake fluid prior to assembly. **NEVER USE BRAKE PASTE!!**
- Catch all brake fluid which escapes the system during repair work. Do not permit brake fluid to contact the vehicle's painted surfaces.
- Always counterhold fittings when loosening or tightening brake pipe connections.

Installation of Damper:

- Remove the following components from the vehicle:
 - CD changer with bracket (if installed)
 - Luggage compartment carpet
 - Front inside cover
 - Spare tire
 - Cover for the ABS hydraulic control unit
- Cover the vehicle battery and unplug the 2 pin plug on the hydraulic brake booster pump (Arrow b Figure 2).
- Remove all pressure from the brake booster system by pumping the brake pedal approximately 25 times or until the brake pedal becomes hard.

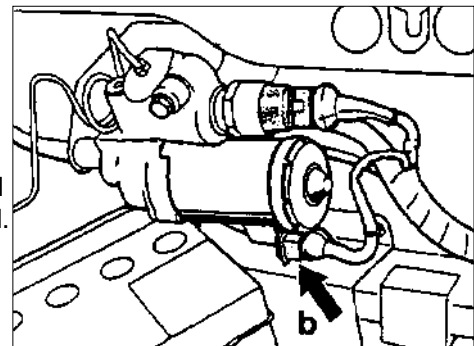

Figure 2



Technical Bulletin

Model
6 Cyl.

Group
4

Subject
Operating Noise of Hydraulic Brake
Booster Pump

Part Identifier
4761

Number
9506

Repair Procedure: (cont'd)

The securing bushings (quantity 3 of 6 and 6a in Figure 3) for the hydraulic pump must be replaced with the new version (black in color).

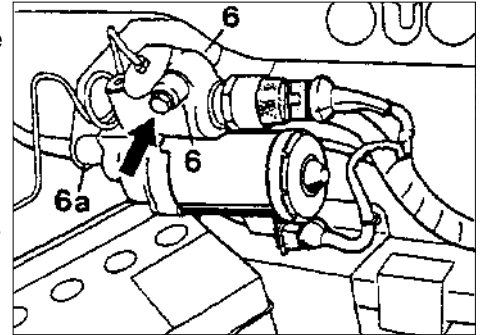

Figure 3

- Remove the bolt (arrow in Figure 3), and **without** loosening the hydraulic lines pull the pump off the mounting brace.

- Remove the former version bushings and install the new version black bushings.

The black bushings are stiffer to accommodate the additional weight of the damper.

- Reinstall the pump onto the mounting brace. Secure the pump with the mounting bolt (arrow in Figure 3) and torque to 10 - 13 Nm (7.2 - 9.4 ftlbs).

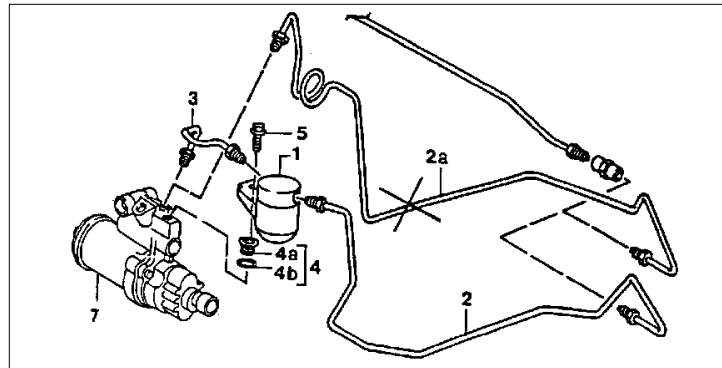

Figure 4

- Remove the blind plug (4a in Figure 4) from the pump with a T45 Torx bit and discard.

- Install the repair set consisting of an inside threaded plug and O-ring (bracket 4 in Figure 4) into the pump. Be certain to lubricate the new O-ring with DOT 4 brake fluid prior to installation. Torque the threaded plug into the pump with an 8 mm allen wrench to 20 Nm + 6 Nm (14.4 ftlbs + 4.3 ftlbs).

- Loosen the long pressure line (2a in Figure 4) and bend upwards. Catch the escaping brake fluid and cap the line.

PORSCHE
CARS
NORTH
AMERICA
INC.



Technical Bulletin

Model
6 Cyl.

Group
4

Subject
Operating Noise of Hydraulic Brake
Booster Pump

Part Identifier
4761

Number
9506

Repair Procedure: (cont'd)

- Install the short pressure line (3 in Figure 5) onto the pump and finger tighten only.

- Remove the two plastic plugs from the damper (1 in Figure 5). Install the other side of the short pressure line into the damper and finger tighten only.

- Secure the damper to the pump using the bolt (5 in Figure 5) and install into the threaded plug. Torque the bolt to 9.7 Nm (11.5 ftlbs).

- Tighten both connections on the short pressure line (arrows in Figure 5) to 14 - 16 Nm (10 - 11.5 ftlbs).

- Unclip the existing long hydraulic line (2a in Figure 4) from the body wall and remove. Catch any escaping brake fluid.

- Install the new hydraulic line into the body wall clips. If necessary, bend the line carefully to fit the clips. The new hydraulic line (2 in Figure 6) is now routed behind the plastic supply line (Arrow a in Figure 6). In the previous version, the old hydraulic line was routed in front of the plastic supply line.

- Connect and torque both sides of the new hydraulic line to 14 - 16 Nm (10 - 11.5 ftlbs).

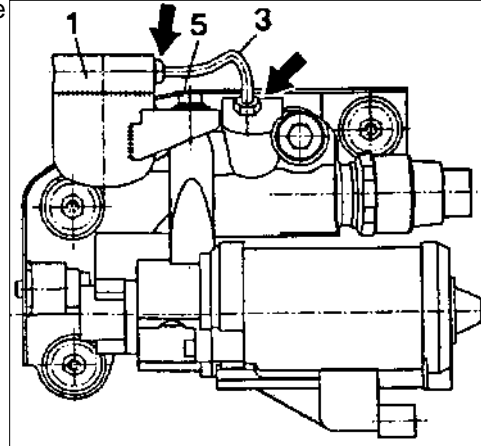

Figure 5

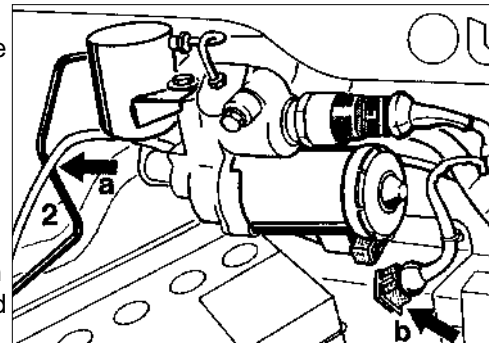

Figure 6



Technical Bulletin	Model 6 Cyl.	Group 4
Subject Operating Noise of Hydraulic Brake Booster Pump	Part Identifier 4761	Number 9506

Repair Procedure: (cont,d)

- Be certain the 2 pin plug for the brake assist pump is still disconnected.
- Bleed the brake booster circuit according to the workshop manual Volume IV, Group 47, pages 47-15 to 47-17.
- Check all connections for leakage and correct if necessary.
- Reconnect the 2 pin plug.
- Reinstall the cover for the ABS hydraulic control unit, spare tire, front inside cover, and trunk carpet. Reinstall CD changer if equipped.

Labor Information:

47 61 15 00	130 TU	Install damper and bleed booster circuit. (without CD changer)
47 61 15 01	160 TU	Install damper and bleed booster circuit. (with CD changer)

Important Notice: Porsche Cars N.A Technical Bulletins are intended for use by professional technicians, not a "Do-it-yourselfer." They are written to inform these technicians of conditions that may occur on some vehicles, or to provide information that could assist in the proper service of a vehicle. Special tools may be required to perform certain operations identified in these bulletins. Use of tools and procedures other than those recommended in these bulletins may be detrimental to the safe operation of your vehicle. Properly trained technicians have the equipment, tools, safety instructions and know-how to do a job properly and safely. If a condition is described, do not assume that the bulletin applies to your vehicle, or that your vehicle will have that condition. See your Porsche Dealer for information on whether your vehicle may benefit from the information. Part numbers listed in these bulletins are for reference only. Always check with your authorized Porsche dealer to verify correct part numbers. ©1995 Porsche Cars North America, Inc.

Dealership	Service manager _____	Shop foreman _____	Service technician _____	_____	_____
Distribution	Asst. manager _____	Warranty admin. _____	Service technician _____	_____	_____
Routing					

The trademarks Porsche®, Targa®, Carrera®, Tiptronic®, Variocam® and the Porsche Crest are registered trademarks of Dr. Ing. h.c.F. Porsche AG and its affiliate, Porsche Cars North America, Inc.